

Load Cell Pendeo[®] Truck

Digital weighing technology for reliable vehicle weighing



! Advantages

- Easy commissioning
- Efficient use due to transparent data
- Quick repair and maintenance
- Extremely resistant



The digital load cells in the Pendeo[®] Truck series are specially designed for vehicle weighing. They are designed such that, when combined with mounting kits, they can compensate for movement of the bridge structure. In combination with "DAT – Digital Assistance Technology" from Minebea Intec, the Pendeo[®] Truck also allows for the recording of valuable data about the weighing process.

Proven Minebea Intec technology for a wide range of applications

- ! **Robust design** ensures insensitivity to vibration and enables load capacities from 20 to 75 tonnes.
- ! **High corrosion** resistance due to high quality steel alloys ensures extremely long service life
- ! **Faster commissioning and shorter service times** thanks to digital data processing
- ! **Perfectly matched weighing electronics** complete the digital measurement chain.

Technical specifications

General technical data for load cell Pendeo® Truck PR 6224B

Parameters	Description	Abbr.	C3	C6	Unit
Accuracy class			0.015	0.008	%E _{max}
Minimal dead load	Lowest limit of specified measuring range	E _{min}	0		%E _{max}
Maximum capacity	Highest limit of specified measuring range	E _{max}	25, 50, 75		t
Safe load limit	Maximum load possible without irreversible damage	E _{lim}	25 t, 50 t: 150 75 t: 100		%E _{max}
Destructive load	Danger of mechanical destruction	E _d	25 t, 50 t: >300 75 t: >200		%E _{max}
Minimum LC verification	Minimum load cell verification interval, $v_{min} = E_{max}/Y$	Y	14,000	20,000	
Deadload output return	Factor for deadload output return after load (DR= 1/2*E _{max} /Z)	Z	3,000	8,000	
Rated output	Output signal at maximum capacity	C _n	Standardised to E _{max} in (t)		
Tolerance on rated output	Permissible deviation from rated output	d _c	< 0.07	< 0.07	%C _n
Zero output signal	Load cell output signal under unloaded condition	S _{min}	0±1	0±1	%C _n
Reproducibility	Max. change of output signal for repeated loading	ε _R	< 0.005	< 0.005	%C _n
Creep	Max. change of output signal at E _{max} during 30 min.	d _{cr}	< 0.015	< 0.008	%C _n
Non-linearity ¹⁾	Deviation from best straight line through zero	d _{lin}	< 0.01	< 0.01	%C _n
Hysteresis ¹⁾	Max. difference in between loading and unloading	d _{hy}	< 0.0165	< 0.008	%C _n
Temperature effect (TK) of S _{min}	Max. change of S _{min} in B _T	TK _{Smin}	< 0.01	< 0.007	%C _n /10 K
TK of parameter ¹⁾	Max. change of C in B _T	TK _C	< 0.01	< 0.005	%C _n /10 K
Insulation impedance	Between measuring circuit and housing at 50 V _{DC}	R _{IS}	> 1,000 × 10 ⁶		Ω
Nominal supply voltage range	In compliance with the technical data	B _U	12 to 28		V _{DC}
Nominal ambient temperature range	In compliance with the technical data	B _T	-10 to +40		°C
Service temperature range	Continuous operation without damage	B _{TU}	-30 to +70		°C
Storage temperature range	Without electrical and mechanical stress	B _{TI}	-40 to +95		°C
Marginal eccentricity	Accepted distance from measuring axis	S _{ex}	5		mm
Vibration resistance	Resistance against oscillations (IEC 68-2-6-Fc)		20 g, 100 h, 10 to 150 Hz		
Barometric pressure influence	Barometric pressure influence on the output signal	PK _{Smin}	<420		g/kPa
Nominal deflection	Max. elastic deforming under maximum capacity	S _{nom}	25 t: < 0.5 50 t: < 0.8 75 t: < 1.1		mm
Material (housing)	Stainless steel 1.4301, AISI 304				
Protection class	IP66 / IP68 / IP69 (and IP6K6K / IP6K8 / IP6K9K acc. ISO 20653)				
Cables	Length: 16.5 m Diameter: 5.8 mm Cross section: 4 × 0.35 mm ² Material of cable sheathing: TPE				
Bending radius	≥ 30 mm in case of fixed installation ≥ 70 mm in case of flexible installation				

¹⁾ The data for non-linearity (d_{lin}), hysteresis (d_{hy}) and temperature effect on C (TK_C) are typical values. For OIML R60- or NTEP-approved load cells, the sum of these values is within the permissible cumulative error limits.

Mounting kits for load cell Pendeo® PR 6224B

Maximum capacity of the load cell PR 6224B	Mounting kit/accessories	Material	Description/comments	Mounting screws	Height (mm)
25 t–75 t	PR 6021/01N	Electrogalvanised steel, chromated and sealed (RoHS-compliant)	Mounting kit incl. Load disc and base component	M12-8.8	190.5
	PR 6021/03N		Mounting kit incl. Load disc and base component with anti-rotation protection		
	PR 6021/05N		Mounting kit incl. Load disc (turbo load disc) and base component		
	PR 6021/07N		Mounting kit incl. Load disc (turbo load disc) and base component with anti-rotation protection		
	PR 6021/00N		Load disc and base component incl. ground strap	/	/
	PR 6021/02N		Load disc and base component with anti-rotation protection	/	/
	PR 6021/04N		Load disc (turbo load disc) and base component	/	/

Cable junction box PR 6024

Parameters	PR 6024/68S
Number of load cells	1 to 8
Material	1.4404, AISI 316L
Protection class	IP66/IP68/IP69
ATEX approval	Zone 2/22
Service temperature range	-30°C to +80°C
Service temperature range in explosive atmospheres	-20 °C to +60 °C
Storage and transport	-30°C to +80°C
Supply voltage	24 V _{DC}

PR 6024/62S power supply unit

Parameters	PR 6024/62S
Material	1.4301, AISI 304
Protection class	IP66/IP68/IP69
ATEX approval	Zone 2/22
Service temperature range	-30°C to +80°C
Service temperature range in explosive atmospheres	-20 °C to +50 °C
Storage and transport	-30°C to +80°C
Supply voltage	100 to 240 V _{AC} ±10%, 50/60 Hz
Power consumption	Max. 35 VA
Output voltage	24 V _{DC}

Supply and data cable PR 6124

Parameters	PR 6124/xxD	PR 6124/xxP
Cable type	Data cable	Supply cable
Cable diameter	5.8 mm	5.2 mm
Cable inductance	A/C: 0.5 μ H/km A/A: 0.7 μ H/km	/
Bending radius	Fixed installation: 30 mm Repeated bending: 70 mm	Fixed installation: 25 mm Repeated bending: 60 mm
Cable capacity	A/C: <110 pF/m A/A: <60 pF/m	/
Conductivity resistance	$\leq 57 \Omega$ /km	/
Temperature range for operation and storage	Operation: -30°C to +90 °C Storage: -40 °C to +90 °C Short term up to +125°C	Operation: -30°C to +90 °C Storage: -40 °C to +90 °C Short term up to +125°C
Test voltage	A/C: 800 V A/A: 1,200 V VDE 0472 part 509 test type B	/
Resistance to oil	VDE 0472 part 803	VDE 0472 part 803
Resistance to flames	EN 60332 1-2	EN 60332 1-2

Technical diagrams

Load cell Pendeo® Truck PR 6224B

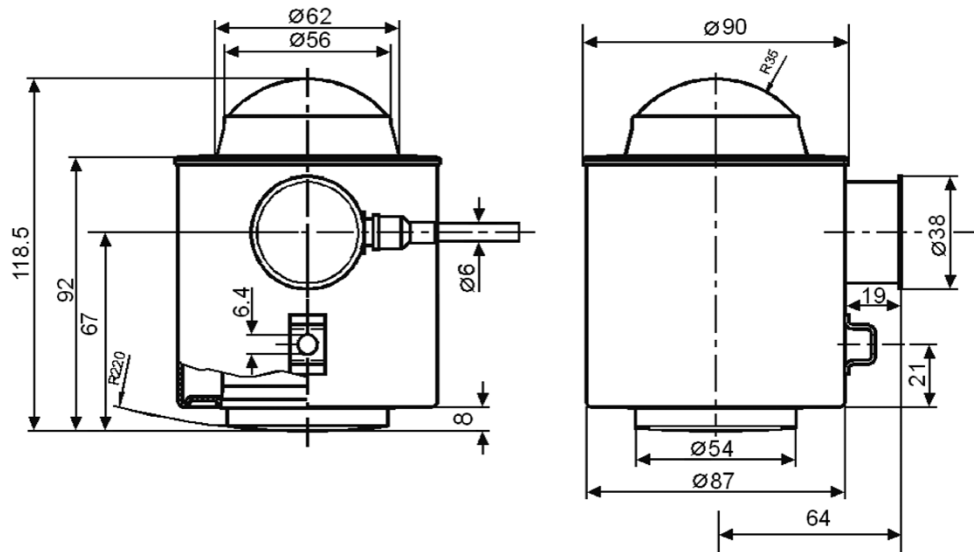

Mounting kits PR 6021

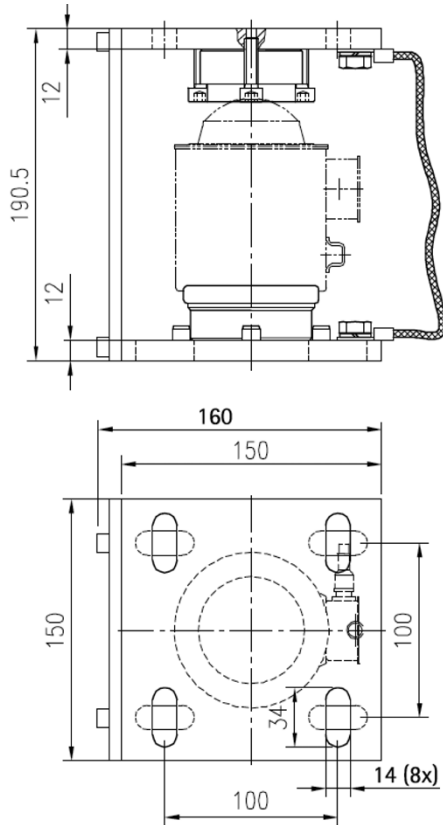

PR 6021/01N, .../03N

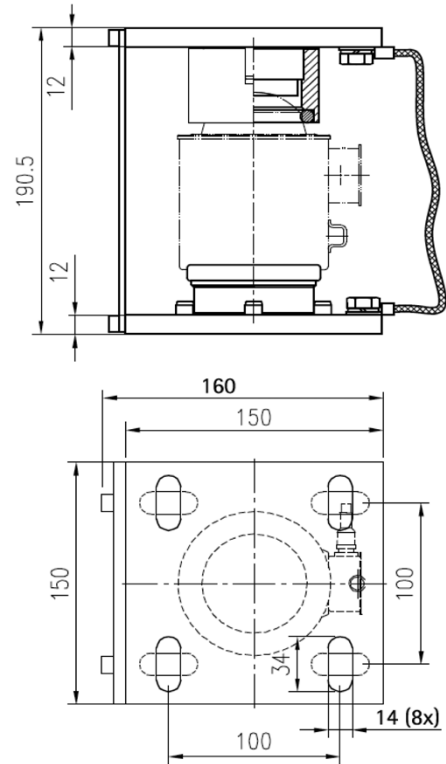

PR 6021/05N, .../07N

Cable junction box PR 6024

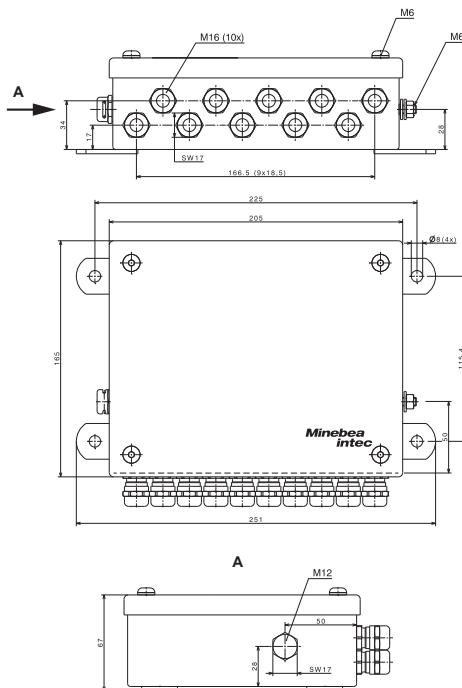

Cable junction box PR 6024/68S

PR 6024/62S power supply unit

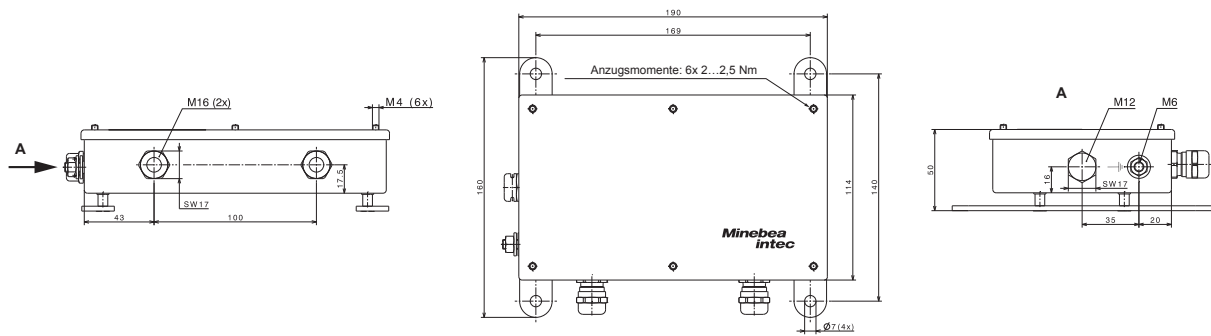

All dimensions in mm

Ex approval

Scope of validity:
PR 6224B/PR 6024



Explosion protection

Load cell Pendeo® Truck certificates

Zone	Marking	Certificate number	For
2	II 3G Ex nA IIC T5 Gc	Manufacturer's declaration	All PR 6224B/xx PR 6024/6x
22	II 3D Ex tc IIIC T90 °C Dc		

Ordering information

Load cell Pendeo® Truck (OIML R60, accuracy class C3= 0.015%, C6= 0.008%)

Type	Order number
PR 6224B/25t C3	940522423325
PR 6224B/25t C6	940522426325
PR 6224B/50t C3	940522423350
PR 6224B/50t C6	940522426350
PR 6224B/75t C3	940522423375
PR 6224B/75t C6	940522426375

Mounting kits

Type	Order number
PR 6021/00N	940536021001
PR 6021/01N	940536021011
PR 6021/02N	940536021021
PR 6021/03N	940536021031
PR 6021/04N	940536021041
PR 6021/05N	940536021051
PR 6021/06N	940536021061
PR 6021/07N	940536021071

Cable junction box, power supply

Type	Order number
PR 6024/68S	940536024684
PR 6024/62S	940536024624

Data and electrical supply cable

Type	Order number
PR 6124/01D (1 m)	940536124013
PR 6124/01P (1 m)	940536124014
PR 6124/31D (30 m)	940536124313
PR 6124/ 31P (30 m)	940536124314
PR 6124/51D (50 m)	940536124513
PR 6124/51P (50 m)	940536124514
PR 6124/12D (100 m)	940536124123
PR 6124/12P (100 m)	940536124124
PR 6124/15D (150 m)	940536124153
PR 6124/15P (150 m)	940536124154
PR 6124/22P (200 m)	940536124224

The products and solutions presented in this data sheet make major contributions in the following sectors:



Food and beverages



Agribusiness



Building materials

The technical data given serves as a product description only and should not be understood as guaranteed properties in the legal sense.

Specifications subject to change without notice.
Rev. 03/2023

Minebea Intec GmbH
Meiendorfer Straße 205 A
22145 Hamburg, Germany
Phone +49.40.67960.303
sales.hh@minebea-intec.com
www.minebea-intec.com